

SF-1420

ACTUATED CEILING INLET WITH ADVANCED OPENING SYSTEM

INSTALLATION INSTRUCTION

Read and save manual for future reference

WARRANTY

Manufacturer warrants each new Inlet manufactured to be free from defects in material or workmanship for one year from and after the date of initial installation by or for the original purchaser. If such a defect is found by the Manufacturer to exist within the one-year period, the Manufacturer will, at its option repair or replace such product free of charge, F.O.B. manufacturer. Labor costs associated with the replacement or repair of the product are not covered by the Manufacturer. Conditions and Limitations: 1. The product must be installed and operated in accordance with the instructions provided or Warranty will be void. 2. Warranty is void if all components of the system are not original equipment supplied by the Manufacturer. 3. Malfunctions or failure resulting from misuse, abuse, negligence, alteration, accident, or lack of proper maintenance shall not be considered defects under the warranty. 4. This Warranty applies only to systems for poultry and swine. Other applications in industry or commerce are not covered by this Warranty. The Manufacturer shall not be liable for a Consequential or Special Damage which any purchaser may suffer or claim to suffer as a result of any defect in the product. "Consequential" or "Special Damages" as used herein include, but are not limited to, lost or damaged products or goods, costs of transportation, lost sales, lost orders, lost income, increased overhead, labor and incidental costs and operational inefficiencies. THIS WARRANTY CONSTITUTES THE MANUFACTURER'S ENTIRE AND SOLE WARRANTY AND THIS MANUFACTURER EXPRESSLY DISCLAIMS ANY AND ALL OTHER WARRANTIES, INCLUDING, BUT NOT LIMITED TO, EXPRESS AND IMPLIED WARRANTIES AS TO MERCHANTABILITY, FITNESS FOR PARTICULAR PURPOSES SOLD AND DESCRIPTION OR QUALITY OF THE PRODUCT FURNISHED HEREUNDER. No one is authorized to modify or extend the terms and conditions of the Warranty in any manner or to offer or grant any other warranties for products in addition to those terms expressly stated above. The Manufacturer reserves the right to change models and specifications at any time without notice or obligation to improve previous models

CAUTION

Read and follow all safety statements, assembly instructions, use and care directions before attempting to install.

RECOMMENDED TOOLS

The following tools may be required depending on your particular installation. Tools not included.

- Power drill
- (8) 2" x #8 wood screws and washers (per inlet)
- Caulk gun
- Caulking
- Tape measure
- Pencil
- Ladder
- Protective Eyewear

ASSEMBLE HARDWARE

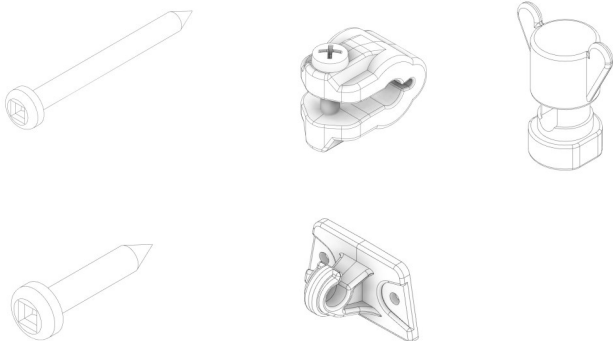

INCLUDED PARTS

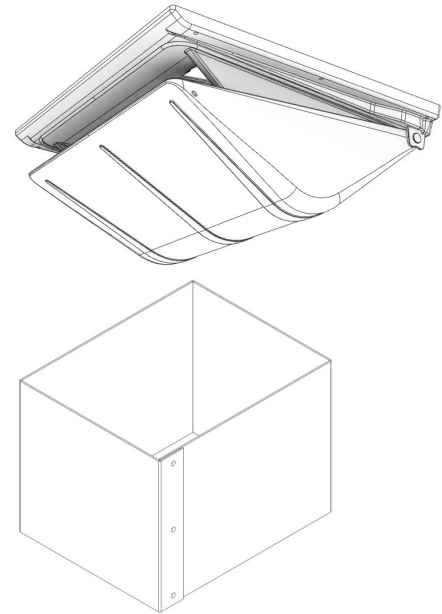

PRE-INSTALLATION PREPERATION

Pre-installation Inspection:

- Inspect inlet condition for breaks and deformed parts
- Rough opening in ceiling (21" W x 17" L)
- Mounting surface should be flat
- Ensure that no debris is hanging out of rough opening hole that can interfere with inlet mechanism
- Determine winch line setup layout. Refer to winch line setup diagram. PRE-INSTALLATION PREPERATION INCLUDED PARTS

Advanced opening opens inlet 2¼" without engaging non-advanced inlets. -350 CFM at .05 static pressure.

WINCH LINE SETUP(s)

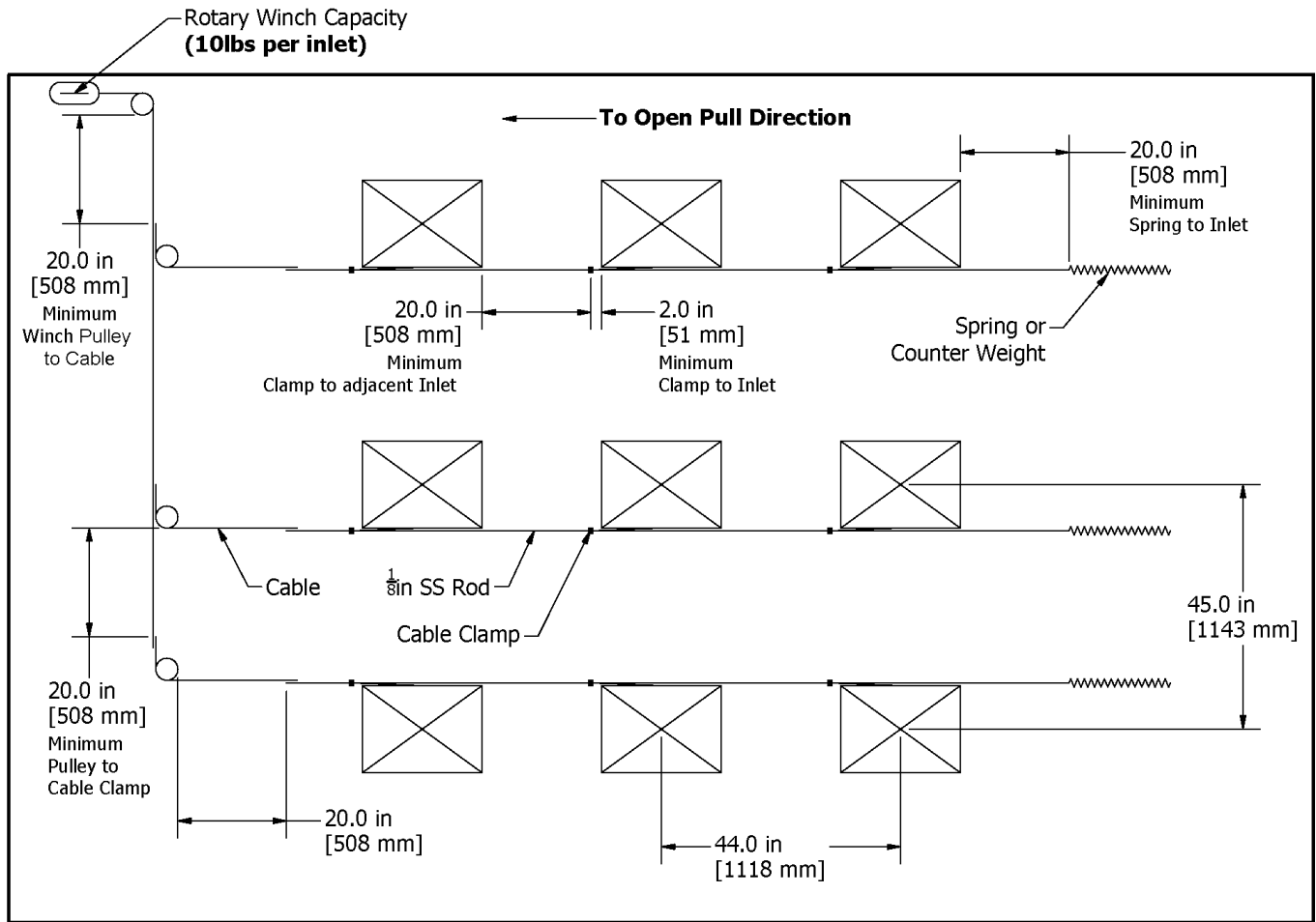

ASSEMBLY INSTRUCTIONS

How to engage door closer

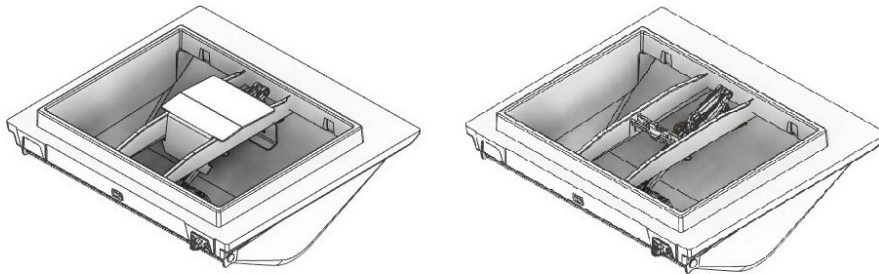

1. Remove cardboard closer retainer

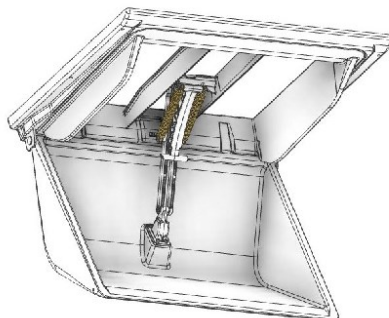

2. Fully open door so that closer assembly can fit through back side of inlet frame

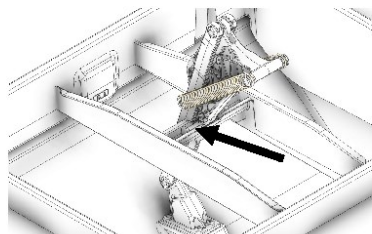

3. Lock door closer into cradle.

STEP 2: Place inlets on floor aligned with rough size openings above and determine which inlets should engage Advanced Opening System (AOS).



STEP 3: For inlets that engage AOS, flip lever up and lock it by securing locking tab.

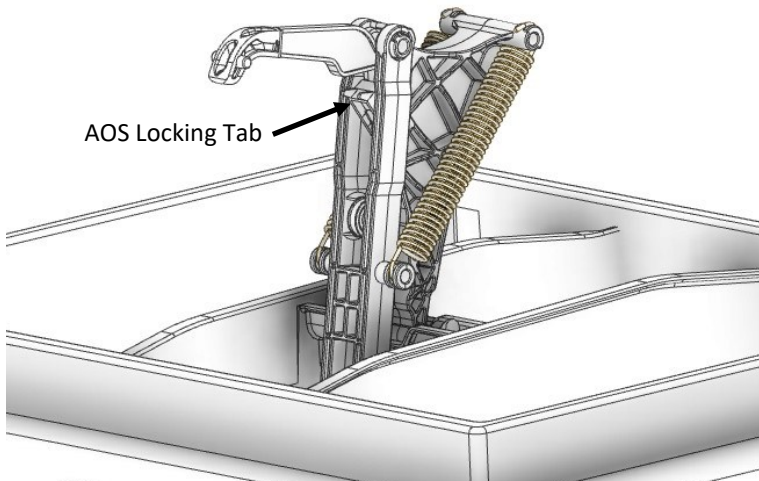

STEP 4: Take note of winch line end of run (spring or weight location). Once determined, attach one rod guide on the inlet back side opposite from end of run using 2 - 1" screws provided in kit.

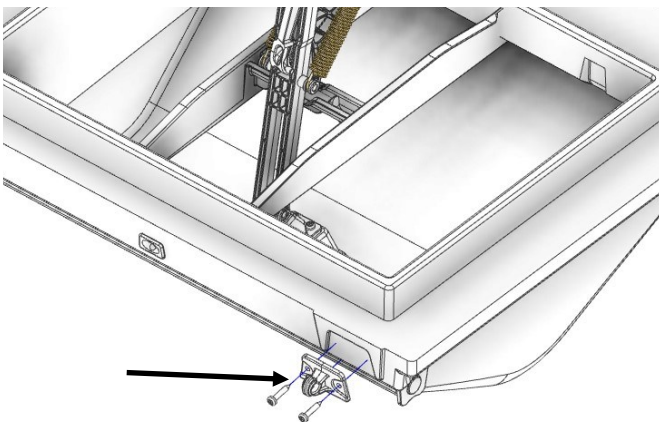

STEP 5: Fasten insulation barrier on inlet. It can be secured using staples

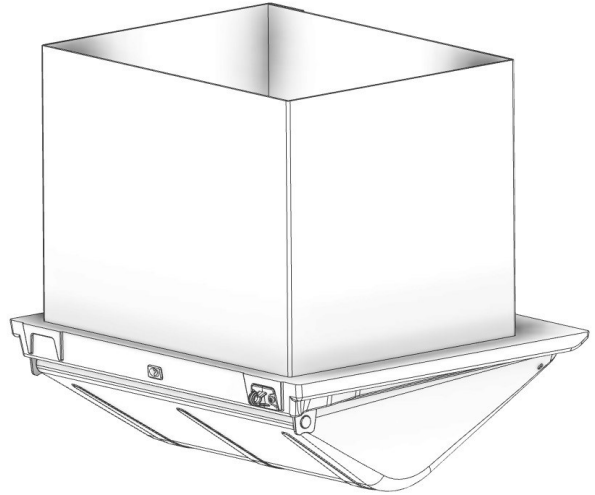

STEP 6: Fasten inlet to ceiling. Insert completed inlet with insulated barrier into properly sized rough opening and fasten with hardware. For ease of installation start all screws while inlet is on the floor using designated center markings.

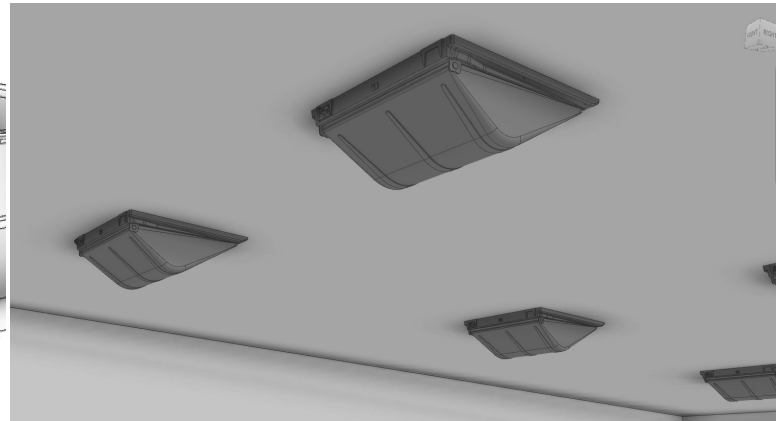

STEP 7: Install rod and winch lines. Keep thumbnut loose for adjustment.

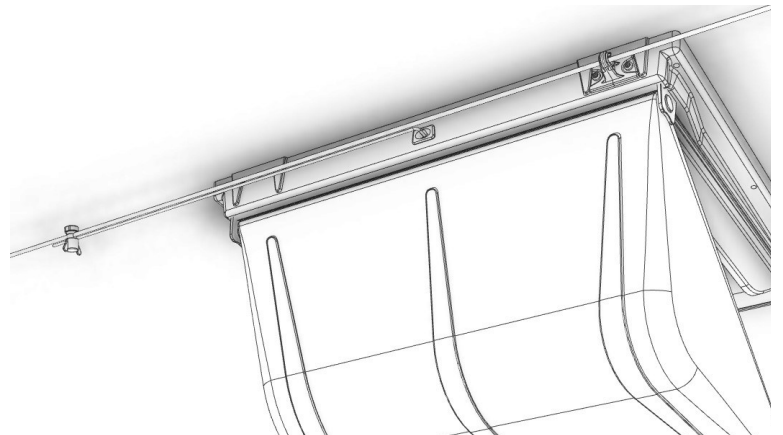

AVANCED OPEING SEQUENCING

STEP 8: With winch open 16" or 3/4 stroke. Prop open lid with 13" wood spacer to create max open. At this position, winch line will be taut with AOS engaged and disengaged. Door with AOS disabled will close faster.

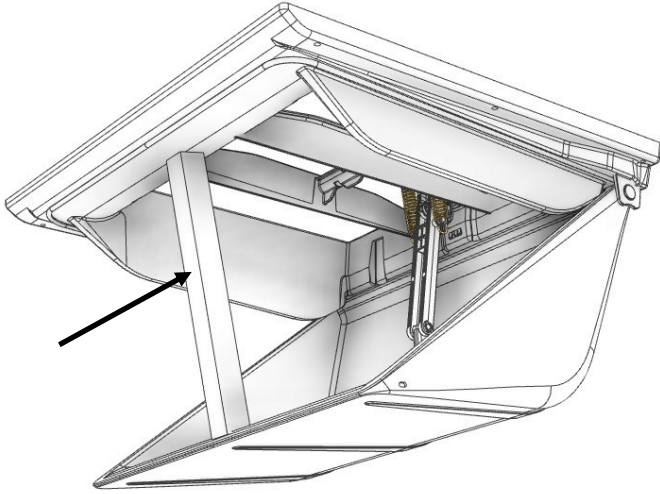

STEP 9: Secure cord to rod using winch line clamp a minimum of 18" from inlet side to ensure that clamp doesn't reach inlet when it's in the closed position. Poly cord should be taut

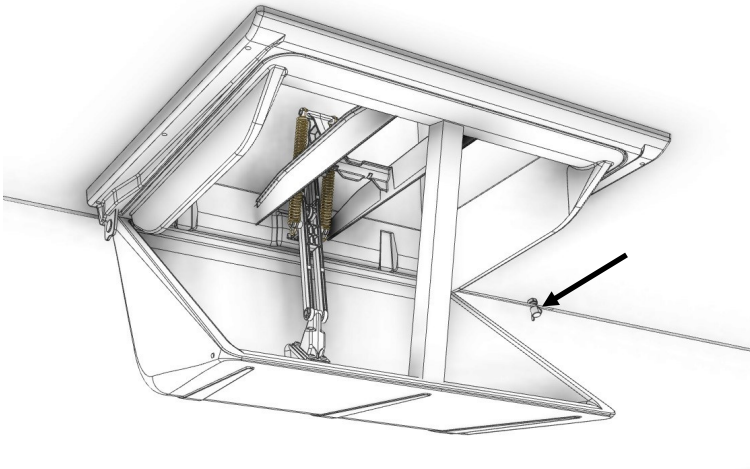

Winch Line Diagram

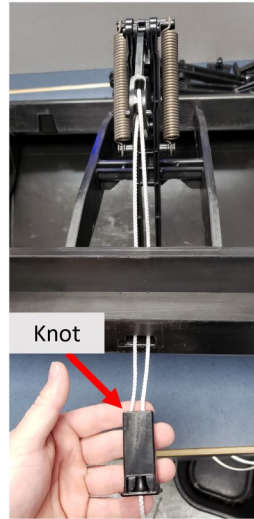
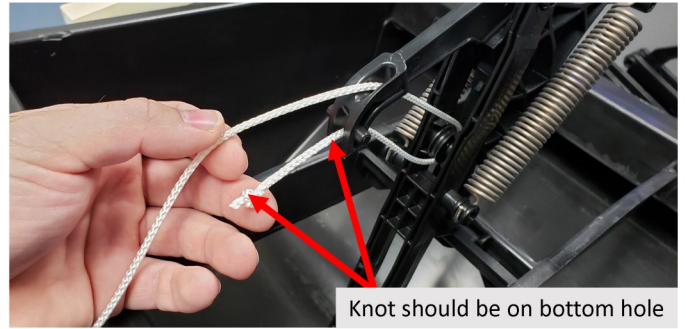

Ensure that winch line has no twist

