

BA-HRV SERIES

Better Air Heat Exchanger System
Technical Manual

Read and Save Manual for Further Reference

INDEX

BA-HRV-50 Physical Specifications	3
BA-HRV-40 Physical Specifications	4
BA-HRV-35 Physical Specifications	5
BA-HRV-22 Physical Specifications	6
BA-HRV-50 Intake Airflow Test	7
BA-HRV-50 Exhaust Airflow Test	8
BA-HRV-40 Intake Airflow Test	9
BA-HRV-40 Exhaust Airflow Test	10
BA-HRV-35 Intake Airflow Test	11
BA-HRV-35 Exhaust Airflow Test	12
BA-HRV-22 Intake Airflow Test	13
BA-HRV-22 Exhaust Airflow Test	14
BA-HRV Electrical Specifications	15
BA-HRV Wiring Diagram	16
Reference Photos	17
BA-HRV Airflow Diagram	18
BA-HRV Standard Building Duct Layout	18
Duct Layout for BA-HRV-50/40/35	19

WARRANTY

Better Air MFG warrants to the original purchaser that its industrial ventilation products, including fans, heat recovery ventilators, ductwork, controls, and associated components (hereafter referred to as "Products"), will be free from defects in materials and workmanship under normal use and service for a period of one year from the date of purchase. During the warranty period, if any defect arises in the materials or workmanship of the Products, Better Air MFG will, at its option, either repair or replace the defective part or product without charge, excluding transportation costs.

This warranty does not cover damage, or defects caused by;

1. Improper installation, misuse, or neglect
2. Accident, fire, flood, or other acts of nature.
3. Unauthorized modifications or repairs.
4. Failure to perform routine maintenance as outlined in the product manual.

To obtain warranty service, the original purchaser must promptly notify Better Air MFG in writing of any claimed defect and provide proof of purchase. Upon receiving notice of a defect Better Air MFG may require the return of the defective product or part for inspection, EXCEPT AS EXPRESSLY SET FORTH HEREIN, BETTER AIR MFG MAKES NO OTHER WARRANTIES, EXPRESS OR IMPLIED, INCLUDING WITHOUT LIMITATION, WARRANTIES OF MERCHANTABILITY OR FITNESS FOR A PARTICULAR PURPOSE.

In no event shall Better Air MFG be liable for any incidental, consequential, or special damages arising out of or in connection with the use or performance of its products, even if Better Air MFG has been advised of the possibility of such damages.

This warranty gives you specific legal rights, and you may also have other rights that vary from region to region or country to country. This warranty is void if the product is not used for the purpose intended. For warranty inquiries or to initiate a warranty claim, please contact:

Better Air MFG
Box 490 MacGregor MB
204.2522333

BA-HRV-50 PHYSICAL SPECIFICATIONS

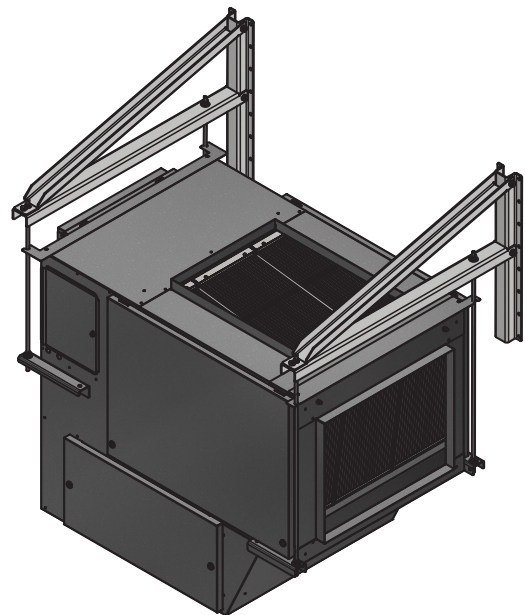
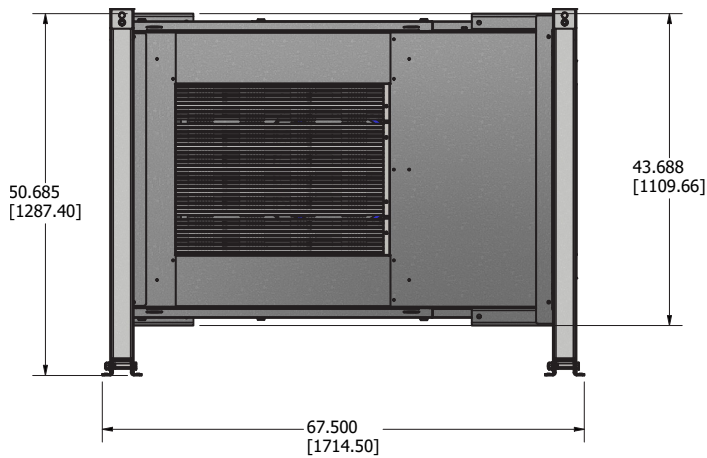
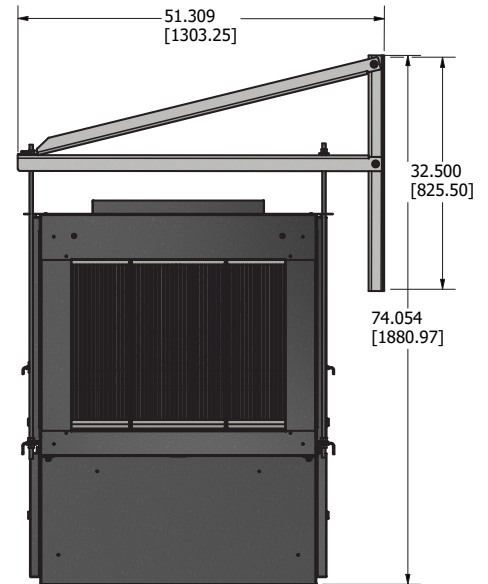
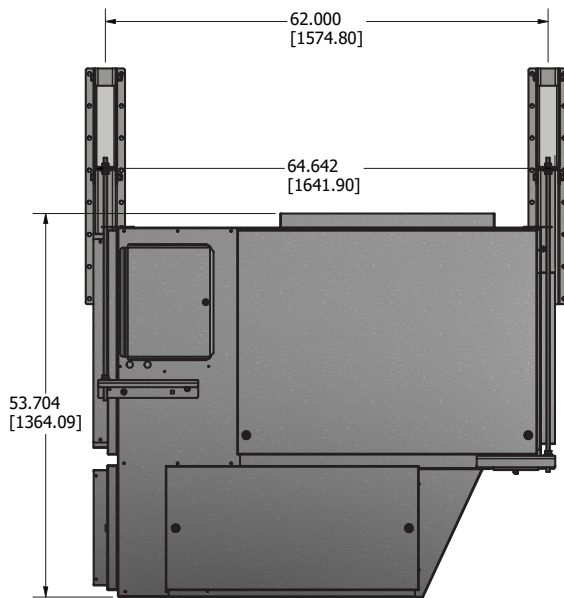

Shipping Weight:
770 lbs

BA-HRV-40 PHYSICAL SPECIFICATIONS

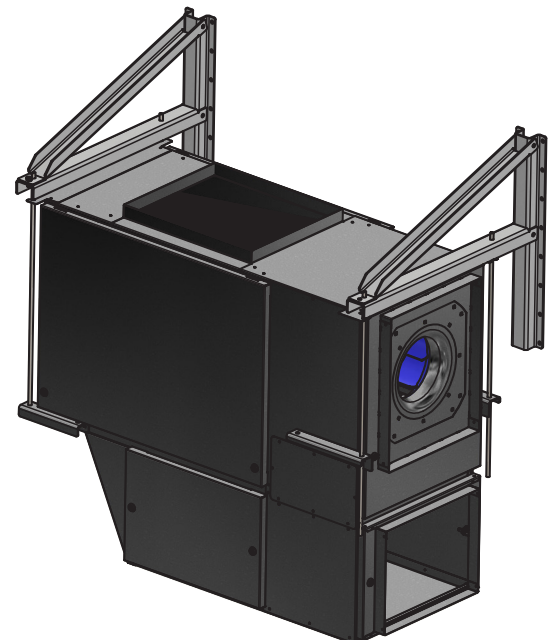
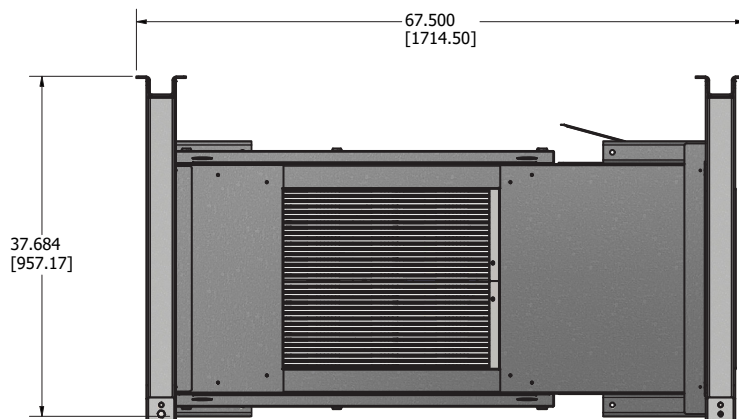
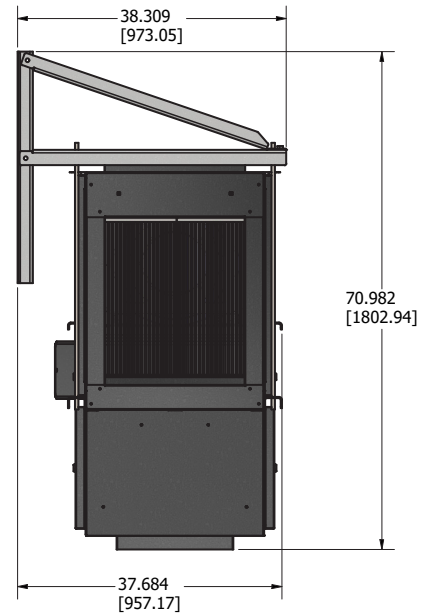
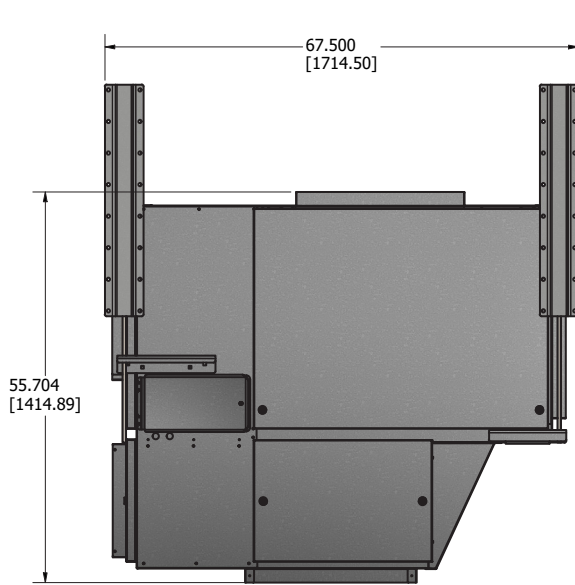

Shipping Weight:
575 lbs

BA-HRV-35 PHYSICAL SPECIFICATIONS

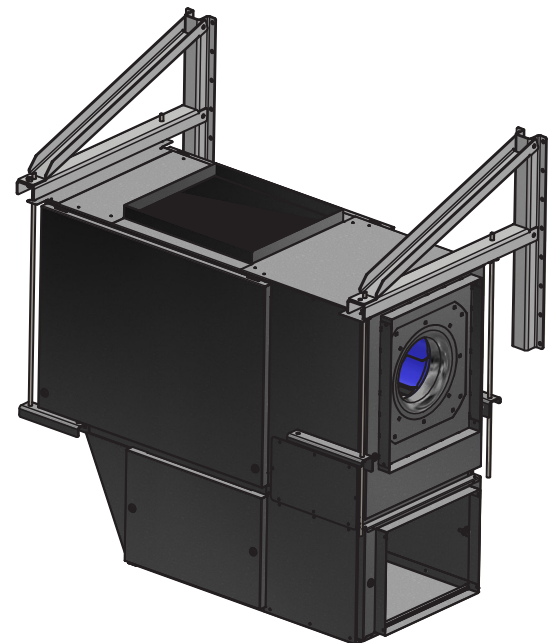
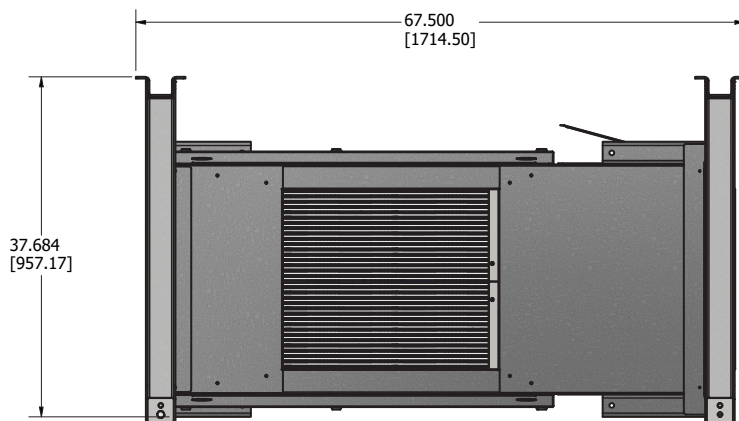
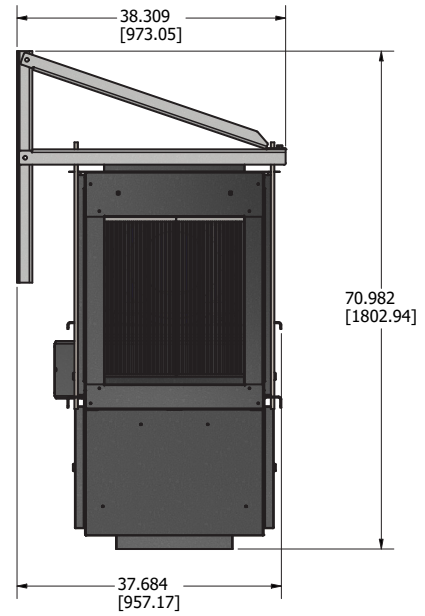
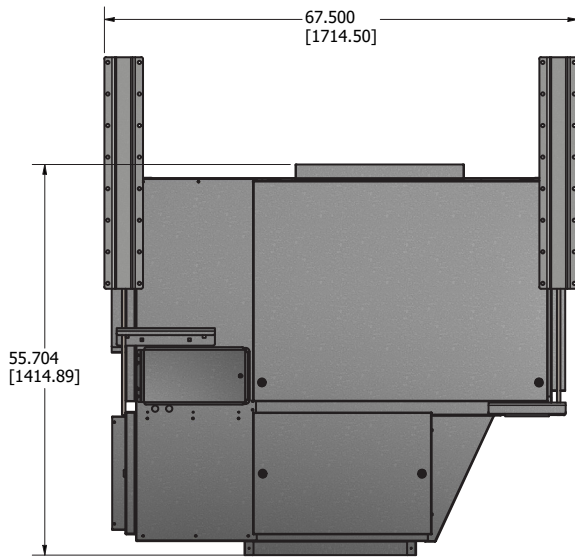

Shipping Weight:
575 lbs

BA-HRV-22 PHYSICAL SPECIFICATIONS

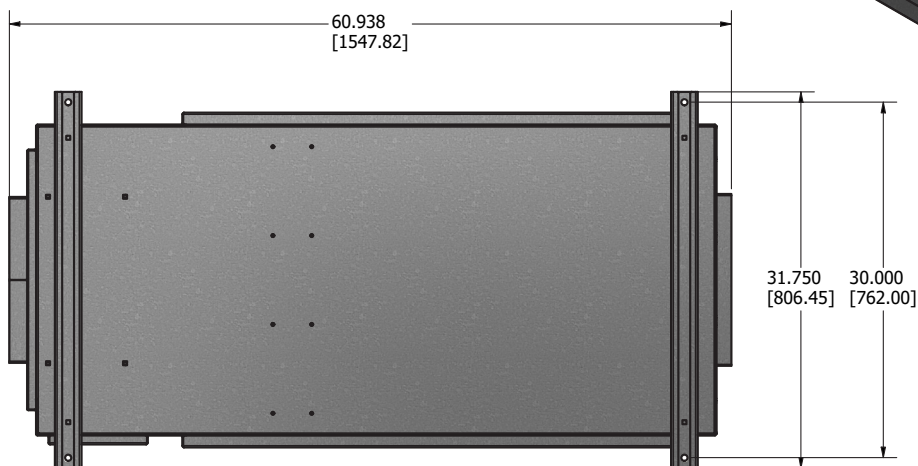
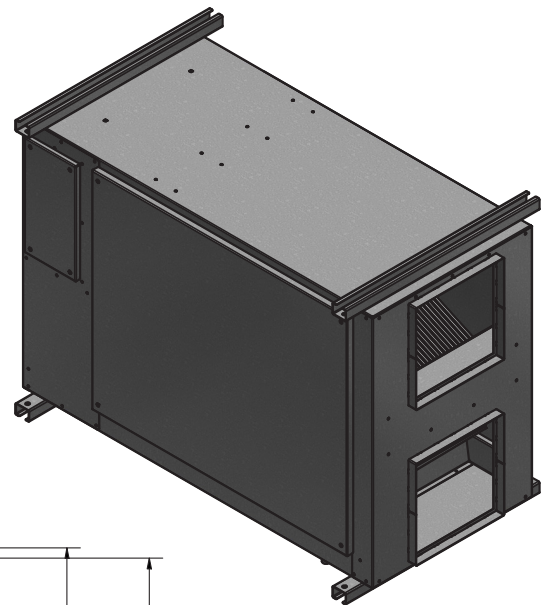
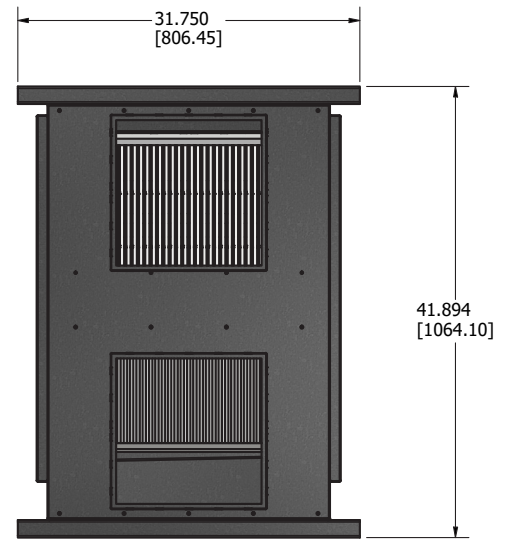
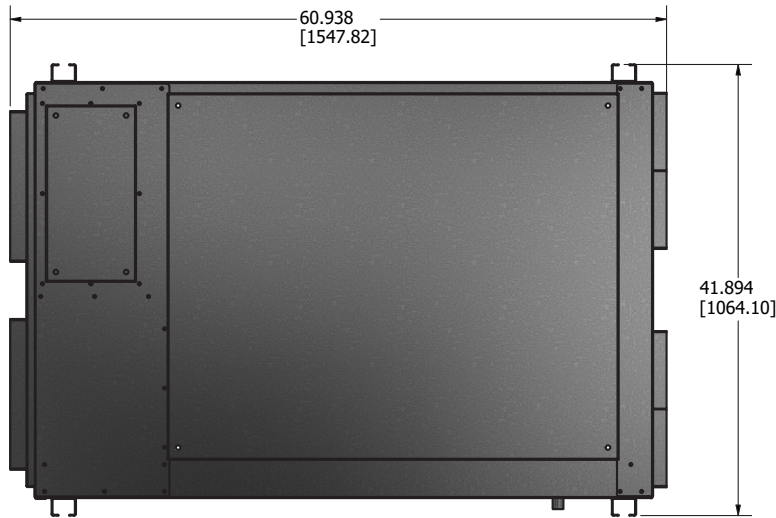

Shipping Weight:
350 lbs

BA-HRV-50 INTAKE AIRFLOW TEST



University of Illinois Department of Agricultural and Biological Engineering
 Bioenvironmental and Structural Systems Lab
 Final Report

Project Number: 19400
 Test Date: June 20, 2019

Heat Recovery Ventilator:

Make- *Better Air*
 Model- *BA-HRV-50 (intake)*
 Type- *Commercial HRV unit*
 Orifice dia.- *9.8"*

Motor:

Make- *Ziehl-Abegg*
 Model- *Part 114877*
 Hp- *3.0 kW*
 RPM- *2590*
 Volts- *200-240*
 Amps- *9.0-7.6*
 Hz- *50 / 60*
 Phase- *3*
 S. F.- *-*

Housing:

Material- *galvanized steel*
 Intake area- *24" x 30"*
 Discharge- *24" x 30"*
 Depth- *65"*

Blade/Wheel:

Number- *7*
 Shape- *back inclined centrifugal*
 Material- *fiber reinforced*
 diameter- *350 mm*
 clearance- *-*

Guards:

Description- *none*
 Spacing- *-*
 Location- *-*

Notes:

Test Conditions:

T(wb): 66 Barometric pressure, recorded 29.1
 T(db): 76.5 Barometric Pressure, corrected 28.97

Corrected to Standard Air (0.075lb/ft³)

Static Pressure (in.H2O)	Airflow (cfm)	Watts	Test Speed rpm
Full speed -100%			
0.00	4939	2188	2582
0.25	4856	2278	2582
0.50	4762	2362	2581
0.75	4666	2445	2581
1.00	4559	2517	2581
1.25	4469	2589	2582
1.50	4367	2650	2582
1.75	4262	2715	2581
2.00	4144	2783	2582
2.25	4024	2831	2582
2.50	3909	2903	2582
2.75	3803	2958	2581
3.00	3695	3013	2582
3.25	3571	3062	2582
3.50	3429	3097	2582
3.75	3295	3126	2582
4.00	3126	3141	2582
90 % setting			
0.00	4569	1716	2383
0.50	4356	1876	2383
1.00	4144	2006	2383
1.50	3932	2119	2383
2.00	3707	2230	2384
50% setting			
0.00	2414	284	1266
0.50	2016	341	1266
1.00	1533	378	1266
100% 1 opening			
0.00	4837	2275	2570

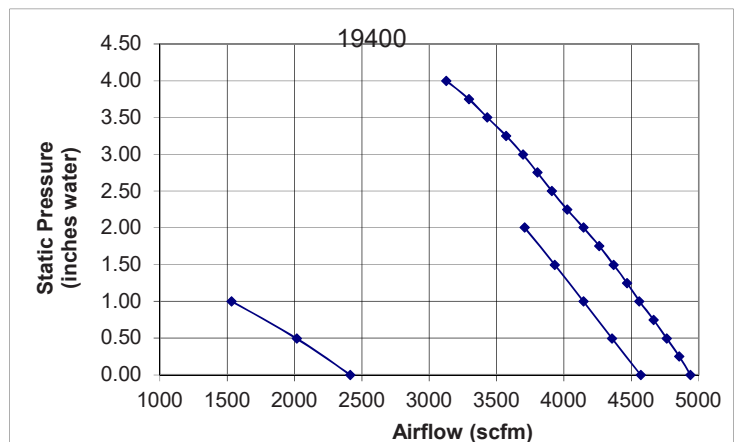

BA-HRV-50 EXHAUST AIRFLOW TEST



University of Illinois Department of Agricultural and Biological Engineering
 Bioenvironmental and Structural Systems Lab
 Final Report

Project Number: 19393
 Test Date: June 19, 2019

Heat Recovery Ventilator:

Make- *Better Air*
 Model- *BA-HRV-50 (exhaust)*
 Type- *Commercial HRV unit*
 Orifice dia.- *9.8"*

Motor:

Make- *Ziehl-Abegg*
 Model- *Part 114877*
 Hp- *3.0 kW*
 RPM- *2590*
 Volts- *200-240*
 Amps- *9.0-7.6*
 Hz- *50 / 60*
 Phase- *3*
 S. F.- *-*

Housing:

Material- *galvanized steel*
 Intake area- *24" x 30"*
 Discharge- *24" x 30"*
 Depth- *65"*

Blade/Wheel:

Number- *7*
 Shape- *back inclined centrifugal*
 Material- *fiber reinforced*
 diameter- *400 mm*
 clearance- *-*

Guards:

Description- *none*
 Spacing- *-*
 Location- *-*

Notes:

Test Conditions:

T(wb): 66.5 Barometric pressure, recorded 29.14
 T(db): 77 Barometric Pressure, corrected 29.01

Corrected to Standard Air (0.075lb/ft³)

Static Pressure (in.H2O)	Airflow (cfm)	Watts	Test Speed rpm
Full speed -100%			
0.00	5073	2157	2595
0.25	5002	2234	-
0.50	4929	2298	-
0.75	4846	2377	-
1.00	4743	2453	-
1.25	4647	2510	-
1.50	4548	2580	-
1.75	4387	2628	-
2.00	4283	2689	-
2.25	4154	2738	-
2.50	4011	2797	-
2.75	3815	2836	-
3.00	3658	2870	-
3.25	3442	2897	-
3.50	3281	2911	-
3.75	3098	2974	-
4.00	2855	2978	-
90 % setting			
0.00	4656	1708	2395
0.50	4489	1840	-
1.00	4262	1964	-
1.50	4033	2062	-
2.00	3719	2148	-
50% setting			
0.00	2439	287	1271
0.50	2084	342	-
1.00	1555	378	-

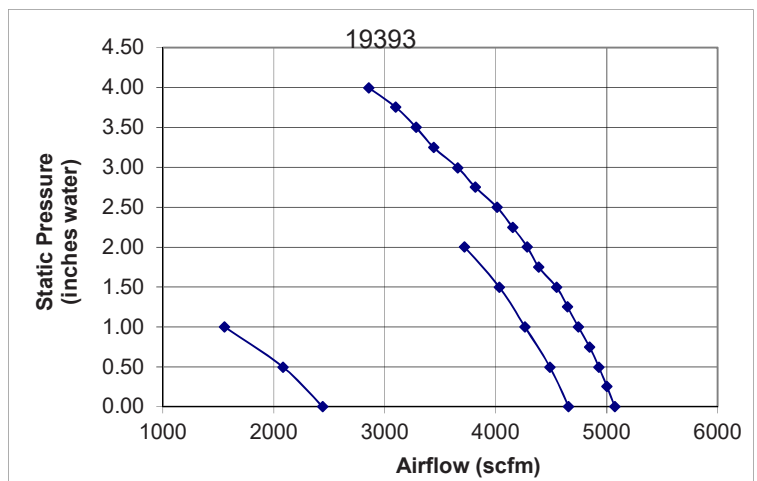

BA-HRV-40 INTAKE AIRFLOW TEST



University of Illinois Department of Agricultural and Biological Engineering
 Bioenvironmental and Structural Systems Lab
 Final Report

Project Number: 19405
 Test Date: June 20, 2019

Heat Recovery Ventilator:

Make- Better Air
 Model- BA-HRV-40 (intake)
 Type- Commercial HRV unit
 Orifice dia.- 8.5"

Motor:

Make- Ziehl-Abegg
 Model- Part 114869
 Hp- 2.70 kW
 RPM- 3060
 Volts- 200-240
 Amps- 8.6-7.2
 Hz- 50 / 60
 Phase- 3
 S. F.- -

Housing:

Material- galvanized steel
 Intake area- 20" x 24"
 Discharge- 20" x 24"
 Depth- 62"

Blade/Wheel:

Number- 7
 Shape- back inclined centrifugal
 Material- fiber reinforced
 diameter- 350 mm
 clearance- -

Guards:

Description- none
 Spacing- -
 Location- -

Notes:

Test Conditions:

T(wb): 65 Barometric pressure, recorded 29.13
 T(db): 76 Barometric Pressure, corrected 29.01

Corrected to Standard Air (0.075lb/ft³)

Static Pressure (in.H2O)	Airflow (cfm)	Watts	Test Speed rpm
Full speed -100%			
0.00	4016	2191	3067
0.25	3915	2249	3067
0.50	3838	2302	3067
0.75	3754	2366	3067
1.00	3684	2424	3067
1.25	3608	2472	3067
1.50	3529	2532	3067
1.75	3460	2586	3067
2.00	3385	2648	3067
2.25	3307	2700	3067
2.50	3221	2761	3067
2.75	3158	2810	3067
3.00	3062	2854	3067
3.25	2969	2887	3067
3.50	2852	2902	3067
3.75	2745	2908	3067
4.00	2619	2917	3067
90 % setting			
0.00	3727	1739	2841
0.50	3535	1838	2841
1.00	3367	1940	2841
1.50	3209	2041	2841
2.00	3055	2137	2841
70% setting			
0.00	2838	787	2174
0.49	2618	857	2175
1.00	2411	927	2174
1.49	2212	992	2174
1.99	1927	1019	2174
50% setting			
0.00	1948	284	1506
0.49	1647	321	1507
1.00	1294	358	1507
94% setting			
0.00	3976	2137	3034

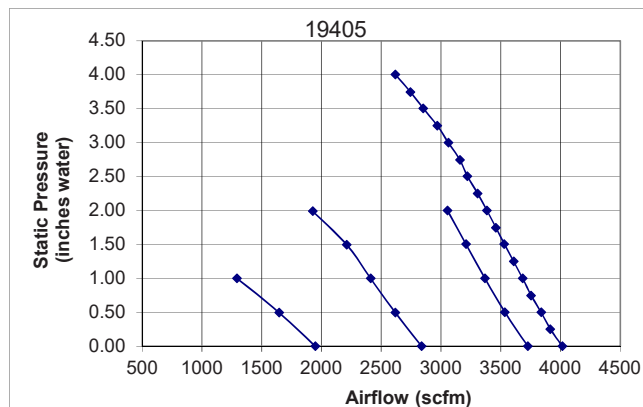

BA-HRV-40 EXHAUST AIRFLOW TEST



University of Illinois Department of Agricultural and Biological Engineering
 Bioenvironmental and Structural Systems Lab
 Final Report

Project Number: 19402
 Test Date: June 20, 2019

Heat Recovery Ventilator:

Make- Better Air
 Model- BA-HRV-40 (exhaust)
 Type- Commercial HRV unit
 Orifice dia.- 8.5"

Blade/Wheel:

Number- 7
 Shape- back inclined centrifugal
 Material- fiber reinforced
 diameter- 350 mm
 clearance- -

Motor:

Make- Ziehl-Abegg
 Model- Part 114869
 Hp- 2.70 kW
 RPM- 3060
 Volts- 200-240
 Amps- 8.6-7.2
 Hz- 50 / 60
 Phase- 3
 S. F.- -

Housing:

Material- galvanized steel
 Intake area- 20" x 24"
 Discharge- 20" x 24"
 Depth- 62"

Guards:

Description- none
 Spacing- -
 Location- -

Notes:

Test Conditions:

T(wb): 66.5 Barometric pressure, recorded 29.06
 T(db): 76.5 Barometric Pressure, corrected 28.93

Corrected to Standard Air (0.075lb/ft³)

Static Pressure (in.H2O)	Airflow (cfm)	Watts	Test Speed rpm
Full speed -100%			
0.00	3994	1925	3068
0.25	3908	1975	-
0.50	3820	2022	-
0.75	3735	2075	-
1.00	3642	2123	-
1.25	3581	2166	-
1.50	3490	2220	-
1.75	3409	2279	-
2.00	3338	2345	-
2.25	3265	2409	-
2.50	3177	2468	-
2.75	3088	2517	-
3.00	2995	2569	-
3.25	2900	2612	-
3.50	2801	2653	-
3.75	2684	2697	-
4.00	2547	2696	-
90 % setting			
0.00	3681	1507	2827
0.50	3502	1594	-
1.00	3326	1684	-
1.50	3165	1794	-
2.00	3015	1906	-
70% setting			
0.00	2787	694	2165
0.50	2569	764	-
1.00	2366	839	-
1.50	2143	905	-
2.00	1862	942	-
50% setting			
0.00	1899	251	1501
0.50	1608	304	-
1.00	1257	341	-

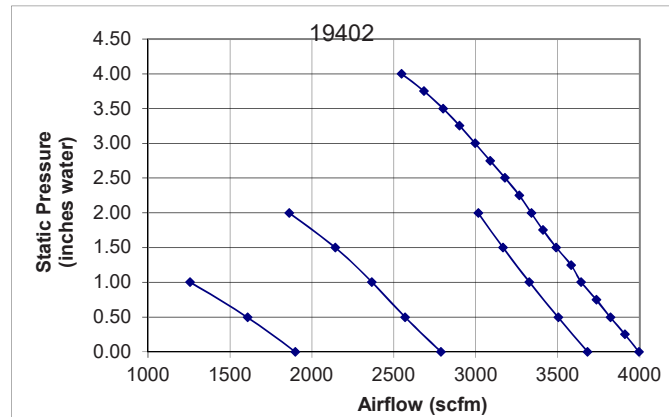

BA-HRV-35 INTAKE AIRFLOW TEST



University of Illinois Department of Agricultural and Biological Engineering
 Bioenvironmental and Structural Systems Lab
 Final Report

Project Number: 19404
 Test Date: June 20, 2019

Heat Recovery Ventilator:

Make- *Better Air*
 Model- *BA-HRV-35 (intake)*
 Type- *Commercial HRV unit*
 Orifice dia.- *8.5"*

Motor:

Make- *Ziehl-Abegg*
 Model- *Part 114498*
 Hp- *1.9 kW*
 RPM- *2720*
 Volts- *200-240*
 Amps- *5.8-4.8*
 Hz- *50 / 60*
 Phase- *3*
 S. F.- *-*

Housing:

Material- *galvanized steel*
 Intake area- *20" x 24"*
 Discharge- *20" x 24"*
 Depth- *62"*

Blade/Wheel:

Number- *7*
 Shape- *back inclined centrifugal*
 Material- *fiber reinforced*
 diameter- *350 mm*
 clearance- *-*

Guards:

Description- *none*
 Spacing- *-*
 Location- *-*

Notes:

Test Conditions:

T(wb): 66 Barometric pressure, recorded 29.1
 T(db): 77 Barometric Pressure, corrected 28.97

Corrected to Standard Air (0.075lb/ft³)

Static Pressure (in.H2O)	Airflow (cfm)	Watts	Test Speed rpm
Full speed -100%			
0.00	3478	1520	2709
0.25	3420	1549	2709
0.50	3336	1600	2710
0.75	3245	1660	2710
1.00	3176	1704	2709
1.25	3093	1753	2710
1.50	3007	1801	2710
1.75	2926	1844	2710
2.00	2843	1882	2706
2.25	2683	1861	2674
2.50	2517	1847	2649
2.75	2388	1842	2637
3.00	2251	1832	2632
3.25	2116	1829	2630
3.49	1991	1833	2634
3.75	1872	1842	2709
4.00	1753	1520	2709
90 % setting			
0.00	3263	1218	2519
0.50	3086	1303	2519
1.00	2899	1397	2519
1.50	2727	1479	2519
2.00	2545	1553	2519
70% setting			
0.00	2497	564	1930
0.50	2270	625	1930
1.00	2037	689	1930
1.50	1767	729	1930
2.00	1382	730	1930
50% setting			
0.00	1721	211	1339
0.50	1386	248	1338
1.00	923	266	1338

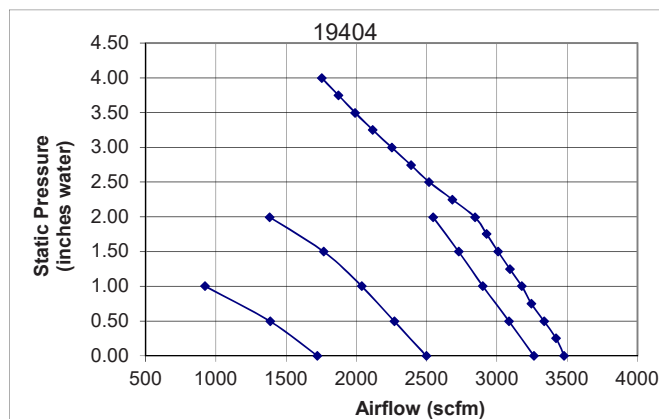

BA-HRV-35 EXHAUST AIRFLOW TEST



University of Illinois Department of Agricultural and Biological Engineering
 Bioenvironmental and Structural Systems Lab
 Final Report

Project Number: 19403
 Test Date: June 20, 2019

Heat Recovery Ventilator:		Motor:	Housing:
Make-	Better Air	Make-	Ziehl-Abegg
Model-	BA-HRV-35 (exhaust)	Model-	Part 114498
Type-	Commercial HRV unit	Hp-	1.9 kW
Orifice dia.-	8.5"	RPM-	2720
		Volts-	200-240
		Amps-	5.8-4.8
Blade/Wheel:		Hz-	50 / 60
Number-	7	Phase-	3
Shape-	back inclined centrifugal	S. F.-	-
Material-	fiber reinforced		
diameter-	350 mm		
clearance-	-		
		Guards:	
		Description-	none
		Spacing-	-
		Location-	-

Notes:

Test Conditions:

T(wb): 66 Barometric pressure, recorded 29.09
 T(db): 77 Barometric Pressure, corrected 28.96

Corrected to Standard Air (0.075lb/ft³)

Static Pressure (in.H2O)	Airflow (cfm)	Watts	Test Speed rpm
Full speed -100%			
0.00	3547	1356	2712
0.25	3455	1401	-
0.50	3361	1430	-
0.75	3239	1485	-
1.00	3151	1525	-
1.25	3061	1566	-
1.50	2974	1613	-
1.75	2871	1665	-
2.00	2779	1702	-
2.25	2668	1742	-
2.50	2561	1774	-
2.75	2432	1807	-
3.00	2264	1831	-
3.25	2151	1858	-
3.50	2024	1872	-
3.75	1928	1878	-
4.00	1796	1885	-
90 % setting			
0.00	3282	1088	2505
0.50	3094	1166	-
1.00	2899	1245	-
1.50	2706	1334	-
2.00	2481	1405	-
70% setting			
0.00	2497	508	1922
0.50	2243	566	-
1.00	1992	631	-
1.50	1692	675	-
2.00	1320	694	-
50% setting			
0.00	1701	193	1331
0.50	1364	230	-
1.00	888	248	-

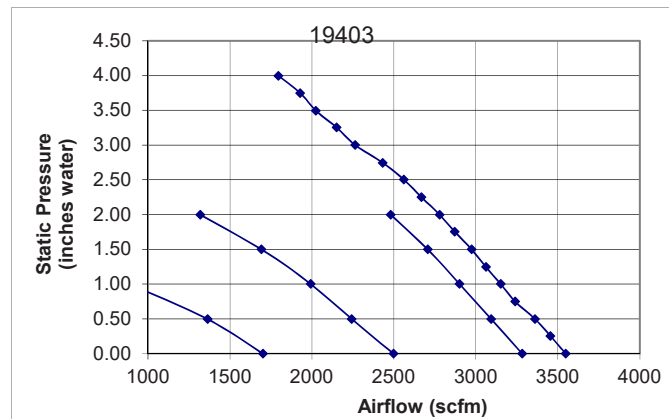

BA-HRV-22 INTAKE AIRFLOW TEST



University of Illinois Department of Agricultural and Biological Engineering
 Bioenvironmental and Structural Systems Lab
 Final Report

Project Number: 24209
Test Date: April 10, 2024

Fan:	Motor:	Shutter:
Make- <i>Better Air</i>	Make- <i>Ziehl-Abegg</i>	Material- <i>none</i>
Model- <i>HRV 2500 Supply fan</i>	Model- <i>E213826ZB-155</i>	# Doors- -
Blade dia.- -	Hp- <i>1.44 kW</i>	# Columns- -
Orifice dia.- -	RPM- -	Door length -
	Volts- <i>200 - 277</i>	Location- -
Wheel:	Amps- <i>5.2</i>	Guards:
Number- <i>7</i>	Hz- <i>50 / 60</i>	Description- <i>none</i>
Shape- <i>inline centrifugal</i>	Phase- <i>1</i>	Spacing- -
Material- <i>fiberglass</i>	S. F.- -	Location- -
	Housing:	Discharge Cone:
	Material- <i>galvanized steel</i>	Depth- <i>none</i>
Drive Sheaves:	Intake area- <i>14" x 14"</i>	Minor dia.- -
Drive dia.- <i>direct</i>	Discharge- <i>14" x 14"</i>	Major dia.- -
Axle dia.- <i>drive</i>	Depth- <i>61"</i>	

Notes: *Heat Recovery Ventilator*

Test Conditions:

T(wb) F: 57.3
 T(db) F: 73.6
 Barometric Pressure 29.12 (In. Hg)

Static Pressure (in.H2O)	Airflow (cfm)	rpm	Volts	Amps	Watts	cfm/Watt	SI Units			
							Static Pressure (Pa)	Airflow (m ³ /hr.)	(m ³ /hr)/W	W/1000m ³ /hr
100 % speed										
0.00	2230	2918	229.6	5.25	1188	1.9	0	3800	3.2	314
0.25	2150		229.6	5.32	1210	1.8	62	3700	3	331
0.50	2070		229.5	5.41	1233	1.7	125	3500	2.9	350
0.75	2020		228.7	5.54	1258	1.6	187	3400	2.7	367
1.00	1960		229.0	5.63	1280	1.5	249	3300	2.6	385
1.25	1900		229.0	5.73	1299	1.5	311	3200	2.5	402
1.50	1830		229.2	5.81	1322	1.4	374	3100	2.3	426
1.75	1750		229.0	5.89	1338	1.3	436	3000	2.2	450
2.00	1670		229.9	5.92	1350	1.2	498	2800	2.1	476
2.50	1460		229.8	5.96	1358	1.1	623	2500	1.8	547
3.00	1220		229.9	5.84	1330	0.9	747	2100	1.6	641
3.50	900		230.2	5.55	1265	0.7	872	1500	1.2	825
3.75	730		230.1	5.27	1199	0.6	934	1200	1	963
90 % speed										
0.00	2000	2630	230.4	3.95	882	2.3	0	3400	3.9	260
0.25	1930		230.5	4.01	898	2.1	62	3300	3.6	274
0.50	1860		230.4	4.10	921	2.0	125	3200	3.4	292
0.75	1790		230.5	4.18	940	1.9	187	3000	3.2	309
1.00	1730		230.4	4.27	963	1.8	249	2900	3	328
1.25	1650		230.3	4.31	970	1.7	311	2800	2.9	346
1.50	1550		230.4	4.41	995	1.6	374	2600	2.6	378
1.75	1470		229.8	4.44	1000	1.5	436	2500	2.5	401
2.00	1340		230.4	4.45	1005	1.3	498	2300	2.3	441
75% speed										
0.00	1640	2165	230.9	2.37	510	3.2	0	2800	5.5	183
0.25	1560		230.9	2.43	525	3.0	62	2600	5	198
0.50	1480		230.8	2.49	539	2.7	125	2500	4.7	214
0.75	1390		230.8	2.56	554	2.5	187	2400	4.3	235
1.00	1290		230.7	2.62	571	2.3	249	2200	3.9	260

BA-HRV-22 EXHAUST AIRFLOW TEST



University of Illinois Department of Agricultural and Biological Engineering
 Bioenvironmental and Structural Systems Lab
 Final Report

Project Number: 24210
 Test Date: April 10, 2024

Fan:	Motor:	Shutter:
Make- <i>Better Air</i>	Make- <i>Ziehl-Abegg</i>	Material- <i>none</i>
Model- <i>HRV 2500 Exhaust fan</i>	Model- <i>E213826ZB-155</i>	# Doors- -
Blade dia.- -	Hp- <i>1.44 kW</i>	# Columns- -
Orifice dia.- -	RPM- -	Door length- -
	Volts- <i>200 - 277</i>	Location- -
Wheel:	Amps- <i>5.2</i>	
Number- <i>7</i>	Hz- <i>50 / 60</i>	Guards:
Shape- <i>inline centrifugal</i>	Phase- <i>1</i>	Description- <i>none</i>
Material- <i>fiberglass</i>	S. F.- -	Spacing- -
		Location- -
	Housing:	
	Material- <i>galvanized steel</i>	Discharge Cone:
Drive Sheaves:	Intake area- <i>14" x 14"</i>	Depth- <i>none</i>
Drive dia.- <i>direct</i>	Discharge- <i>14" x 14"</i>	Minor dia.- -
Axle dia.- <i>drive</i>	Depth- <i>61"</i>	Major dia.- -

Notes: *Heat Recovery Ventilator*

Test Conditions:

T(wb) F: 57.7
 T(db) F: 74.2
 Barometric Pressure 29.10 (In. Hg)

Static Pressure (in.H2O)	Airflow (cfm)	rpm	Volts	Amps	Watts	cfm/Watt	SI Units			
							Static Pressure (Pa)	Airflow (m ³ /hr.)	(m ³ /hr)/W	W/1000m ³ /hr
100 % speed										
0.00	2330	2922	230.5	4.80	1094	2.1	0	4000	3.6	276
0.25	2250		230.4	4.92	1122	2.0	62	3800	3.4	294
0.50	2150		230.3	5.07	1156	1.9	125	3700	3.2	316
0.75	2080		230.3	5.16	1180	1.8	187	3500	3	334
1.00	2000		230.3	5.26	1202	1.7	249	3400	2.8	353
1.25	1930		229.8	5.39	1230	1.6	311	3300	2.7	376
1.50	1830		229.8	5.48	1249	1.5	374	3100	2.5	401
1.75	1750		229.8	5.55	1265	1.4	436	3000	2.4	425
2.00	1650		229.8	5.62	1283	1.3	498	2800	2.2	457
2.50	1440		229.8	5.78	1318	1.1	623	2400	1.9	539
3.00	1220		230.2	5.77	1318	0.9	747	2100	1.6	638
3.50	940		230.2	5.66	1292	0.7	872	1600	1.2	813
3.75	800		230.2	5.49	1253	0.6	934	1400	1.1	925
90 % speed										
0.00	2110	2686	230.8	3.73	845	2.5	0	3600	4.2	235
0.25	2020		230.4	3.85	873	2.3	62	3400	3.9	254
0.50	1940		230.3	3.96	898	2.2	125	3300	3.7	272
0.75	1860		230.3	4.08	927	2.0	187	3200	3.4	293
1.00	1780		230.4	4.17	948	1.9	249	3000	3.2	314
1.25	1690		230.3	4.26	970	1.7	311	2900	3	338
1.50	1600		230.3	4.35	992	1.6	374	2700	2.7	364
1.75	1500		230.0	4.41	1004	1.5	436	2600	2.5	393
2.00	1380		229.8	4.49	1021	1.4	498	2300	2.3	435
75% speed										
0.00	1730	2215	230.9	2.28	494	3.5	0	2900	6	168
0.25	1630		231.1	2.37	517	3.1	62	2800	5.4	187
0.50	1530		230.4	2.47	538	2.8	125	2600	4.8	207
0.75	1410		230.3	2.55	559	2.5	187	2400	4.3	233
1.00	1310		230.3	2.60	571	2.3	249	2200	3.9	256

BA-HRV ELECTRICAL SPECIFICATIONS



	BA-HRV-50	BA-HRV-40	BA-HRV-35	BA-HRV-22
VOLTAGE	208	208	208	230
PHASE	3ph	3ph	3ph	1ph
AMPS	13.2	17.5	12.5	10.4

HMI Comm	Humidity sensor or static pressure	Fan Status	C02 Sensor Dry Contact	24+ for HMI & Sensors only	24- for HMI & Sensors only
----------	------------------------------------	------------	------------------------	----------------------------	----------------------------

BA-HRV WIRING DIAGRAM

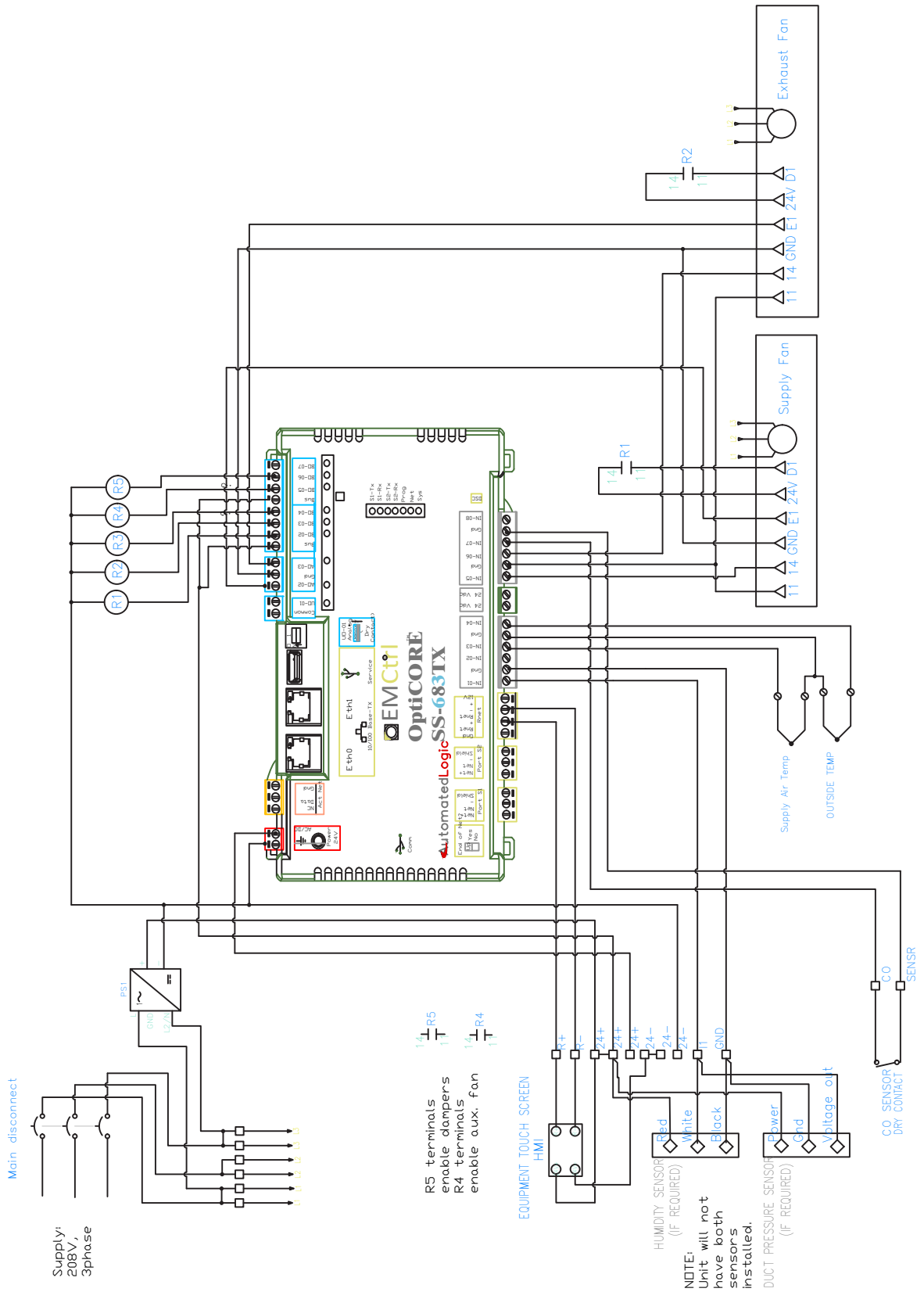

Ethernet ports for Unit Networking

Main Power Connection

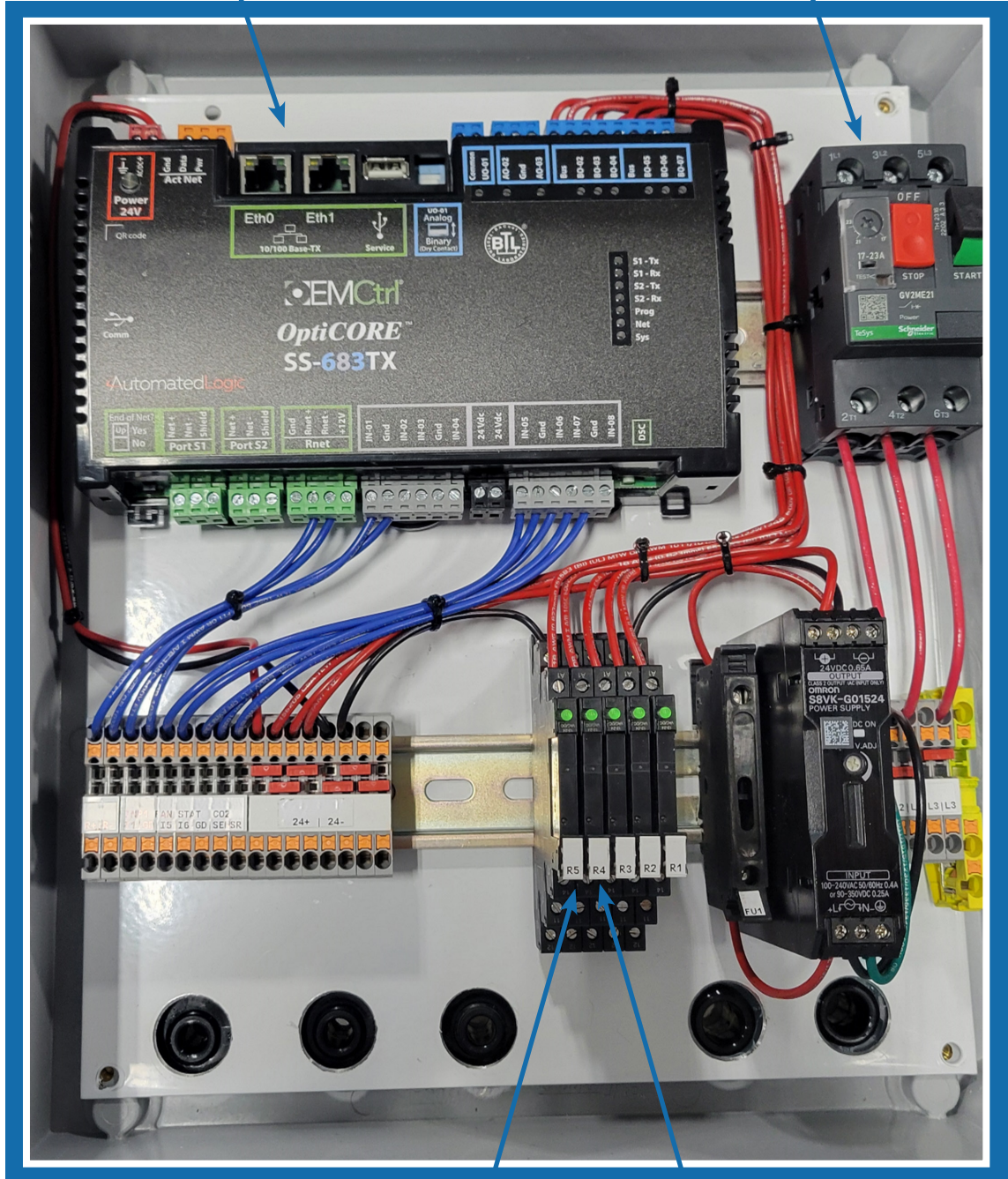

R5

R4

BA-HRV AIRFLOW DIAGRAM

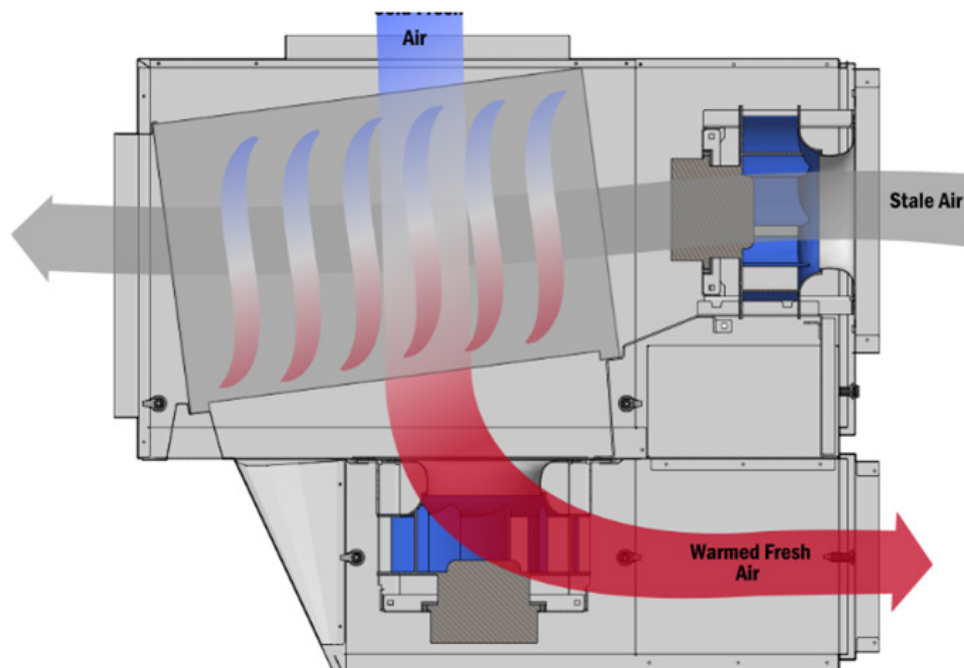

BA-HRV STANDARD BUILDING DUCT LAYOUT

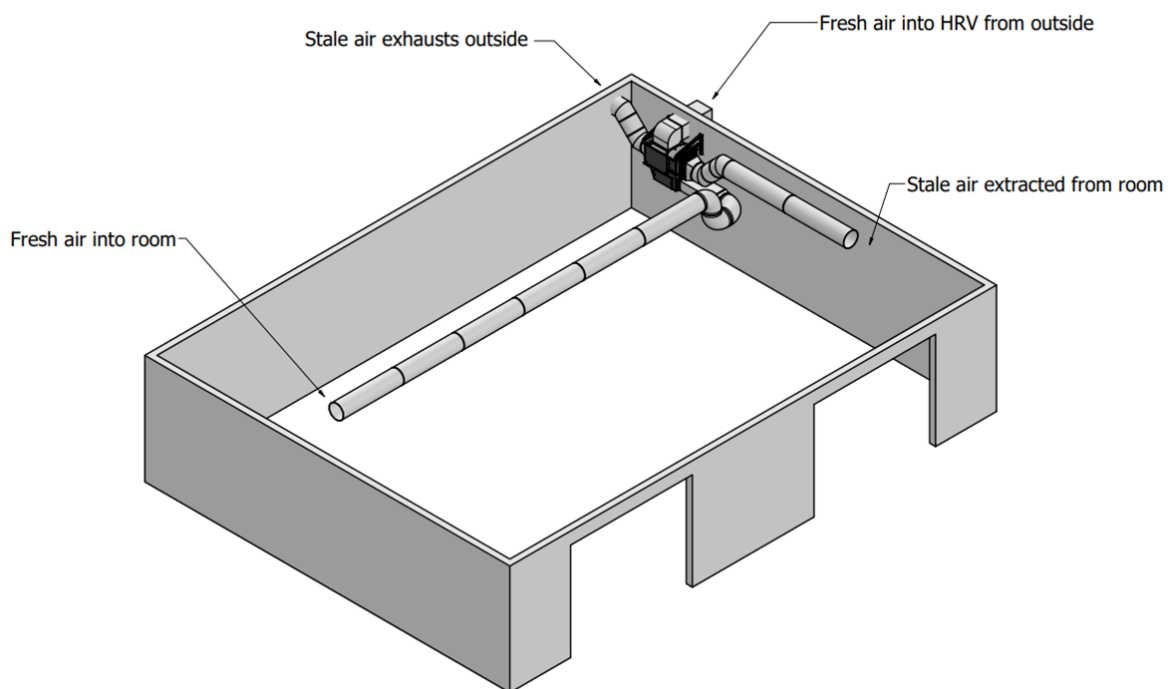

DUCT LAYOUT for BA-HRV-50/40/35



Attach the ducting to the BA-HRV Unit using self tapping screws, or your own preferred Method of installing ducting, Take care as not to damage any part of the BA-HRV Unit as you are installing the duct parts

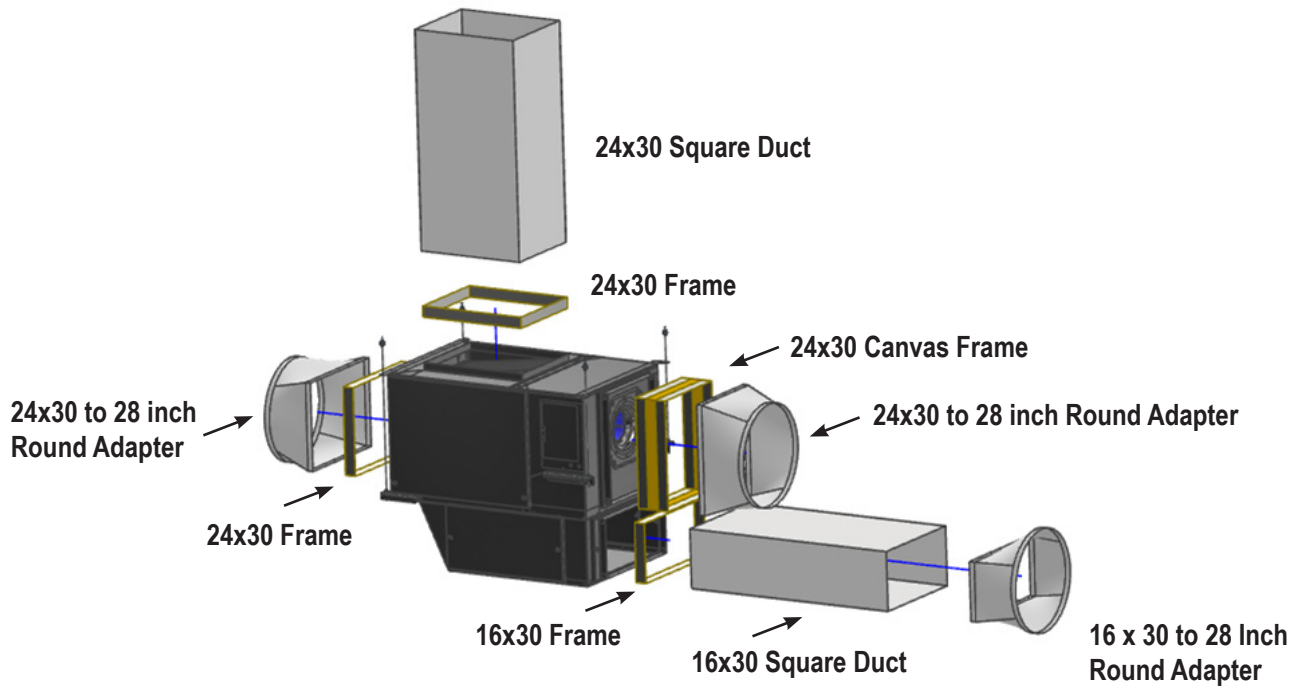

BA-HRV Installed in a washbay



BA-HRV SERIES

Better Air Heat Exchanger System
Technical Manual